

Lodi Downtown Re-Visioning Project

May 14th, 2015, Final Presentation



**DESIGN
CONNECT**

Team Lodi!

Design Connect: Student organization at Cornell University that engages in design and planning projects in the greater Ithaca area.

2015 American Planning Association Outstanding Planning Student Organization

DESIGN
CONNECT



Downtown Re-visioning Project

Project Goal: To create a downtown re-visioning plan that includes both an aesthetic and an economic approach to making the Village of Lodi a healthier place

Client: Seneca Towns Engaging People for Solutions (STEPS)

DESIGN
CONNECT



Recommendation Format



Community Outreach

Site Visits

Getting to Know Lodi!

- Tin Punching at Library
- Spaghetti Dinner at Fire House

Re-visioning Meeting #1

- Question Activity
- Mapping Activity

Re-visioning Meeting #2

- Preliminary Recommendations
- Discussion (Q&a and Critiques)
- Preliminary Design Critique





Community Meeting #1, March 8, 2015 at Lodi Town Hall.



Community Meeting #1
Behavioral Map Activity - Map
Active places ●
Places desired ●



Community Meeting #2, April 16, 2015 at Lodi Fire House.

Getting to Know Lodi!



Tin Punching at Lodi Library.



Spaghetti Dinner at Lodi Fire House.



Being Firefighters! at Lodi Fire House.



Design Charette, March 25, 2015 at Sibley Hall, Cornell University.



Design Charette, March 25, 2015 at Sibley Hall, Cornell University

Recommendations

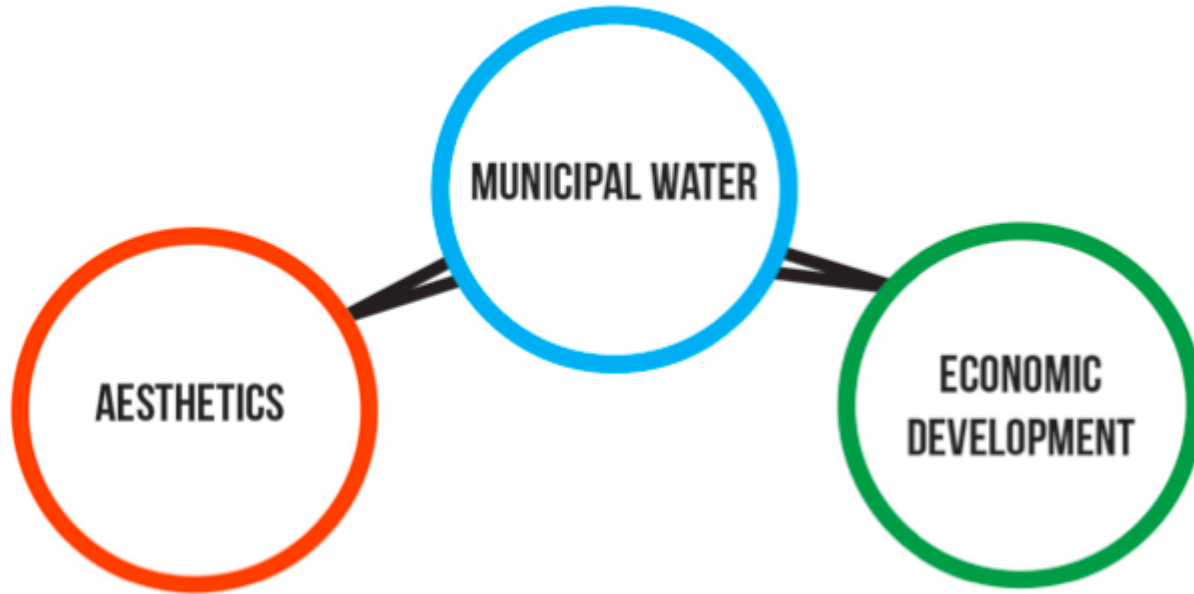

Municipal Water

Current Well Based System

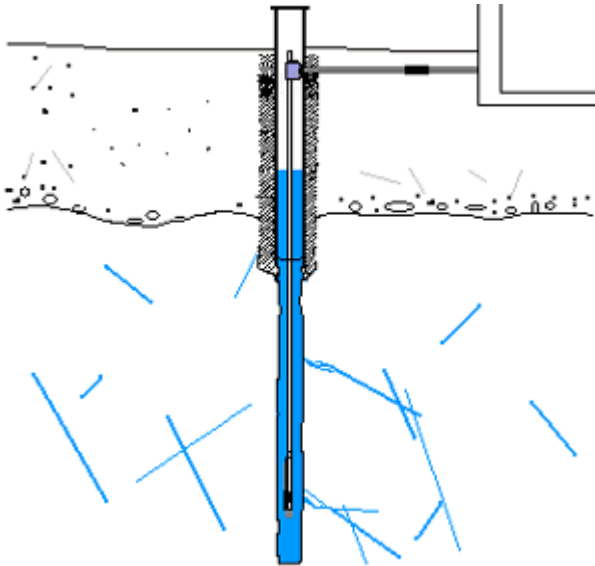

Source: pixshark.com

Schematic Municipal Water System

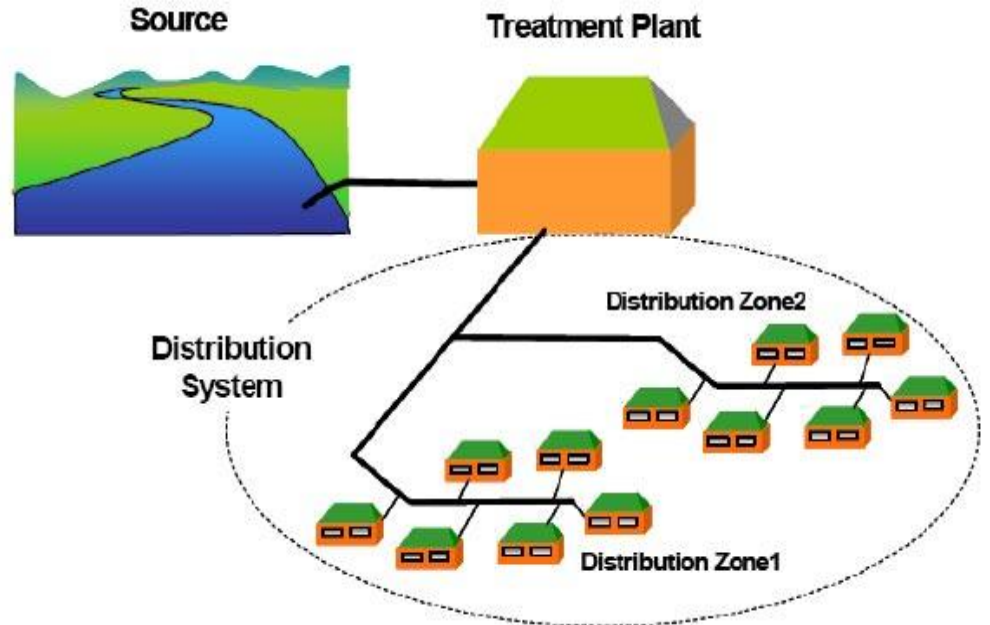

Source: hudsonvalleywaterresources.com

Municipal Water

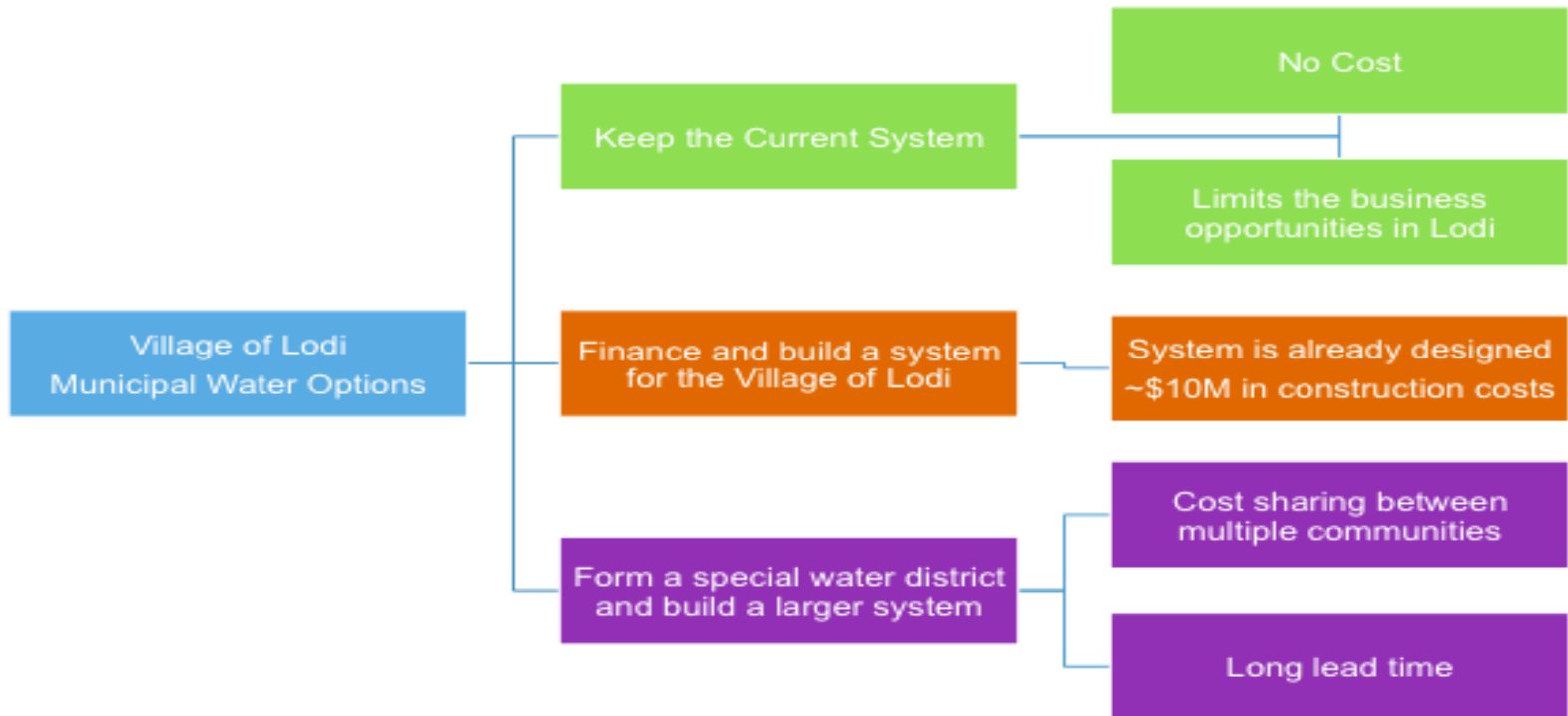

Municipal Water

Case Study: Savona, NY

Setup

- 41 miles from Lodi
- 818 residents

Costs and Timeline

- Total Construction Costs: \$5,500,000
- 3-years from design until completion
- ~\$60,000/year in operating costs

Finances

- \$2.5M in grants (Restore NY)
- \$3M in 0% interest 30-year municipal loan
- Each household pays \$20/month to pay off the loan

Benefits

- Access to clean water
- 15% reduction in home insurance premiums
- 2 new businesses



Water storage vessel in Savona



Savona Pump Station

Economic Development

Asset-Based Approach: a bottom-up approach

- Natural amenities
- Cultural and historic resource
- Human Capital

Existing industries:

- Finger Lakes Food Processing Cluster Initiative
- Wine Cluster

Potential opportunity:

- Recreational Destination
- Retirement Destination

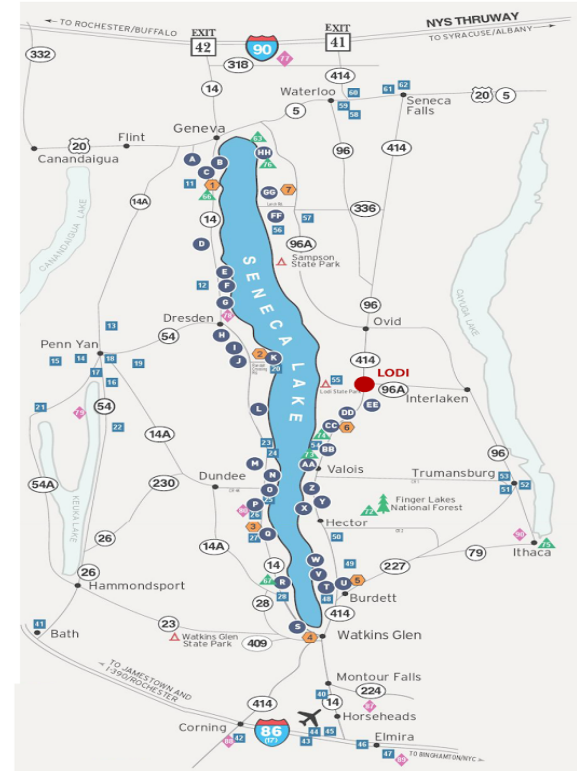

Economic Development

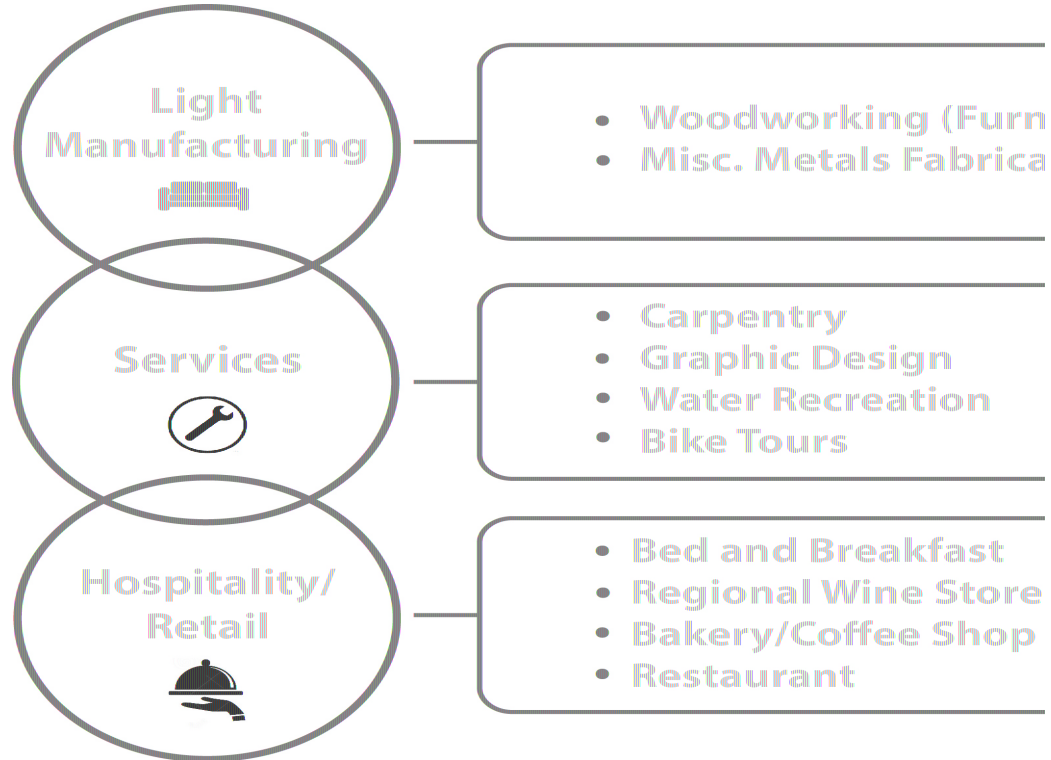

Aesthetics: Elements

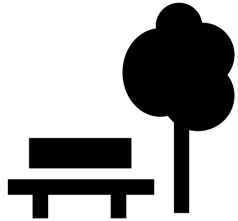

PARKLET



STREET LAMPS



BENCHES

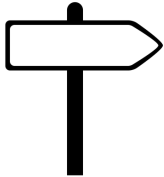

SIGNAGE



**STREET PLANTING
AND BIOSWALES**



MURALS

Aesthetics: Programs



FARMERS MARKET



**COMMUNITY
GARDEN**

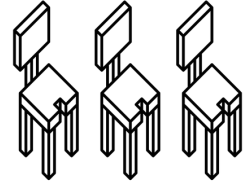

CAFE OUTDOOR SEATING

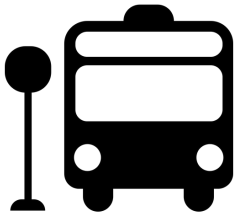

BUS STOP

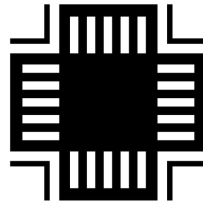

**INTERSECTION
REPAIR**



**SENECA WINE
TASTING ROOM**

Proposed Design Features

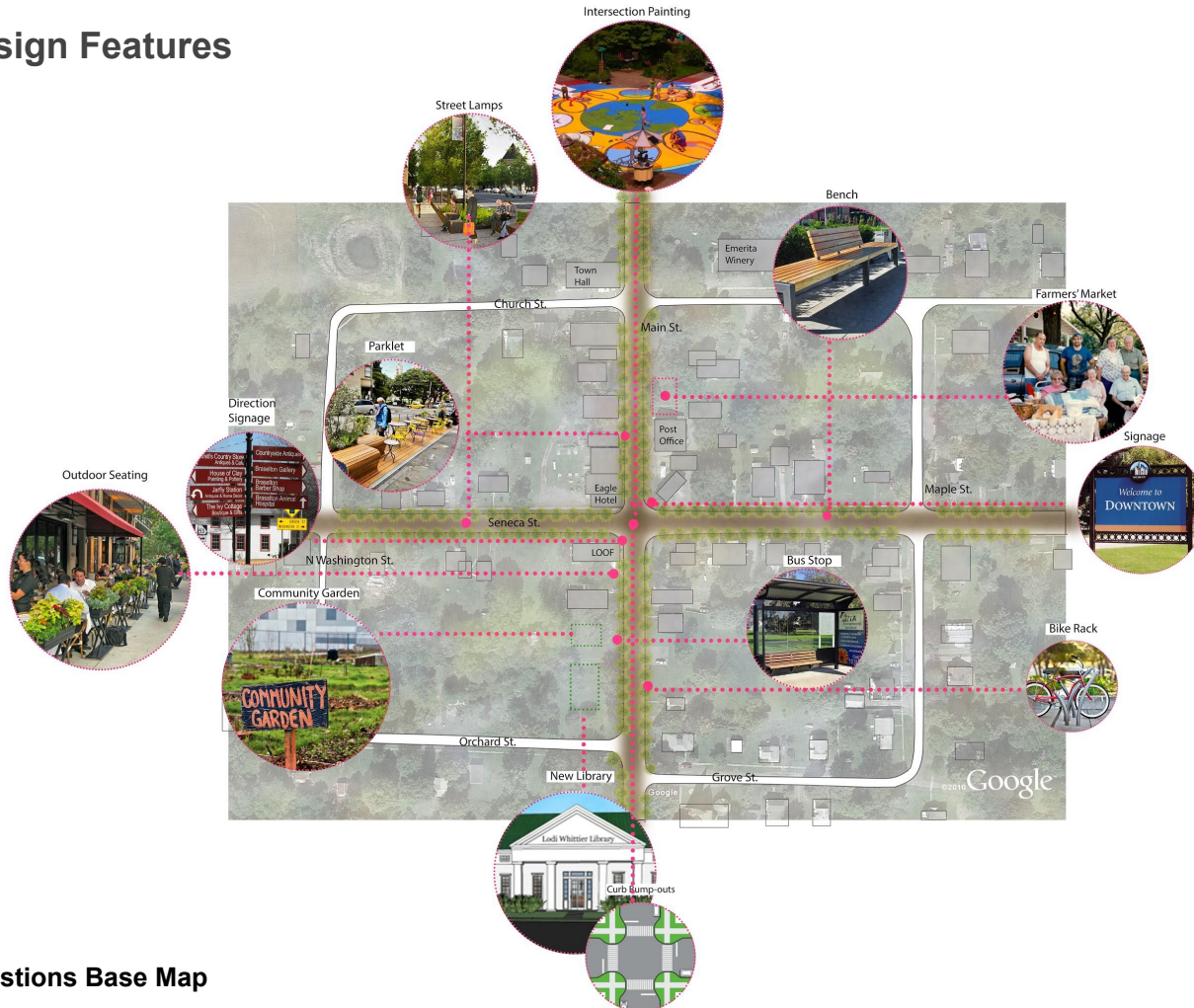

Design Suggestions Base Map





MURALS

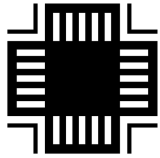

INTERSECTION
REPAIR

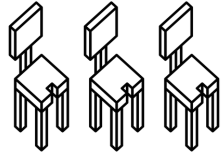

OUTDOOR
SEATING



Streetview Rendering

#1



1000 S. ...
... St.

1000 S. ...
... St.

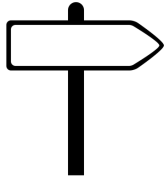

SIGNAGE



STREET LAMPS



Streetview Rendering





**STREET
PLANTING AND
BIOSWALES**



STREET LAMPS



Streetview Rendering



Lodi Library Plot
Now

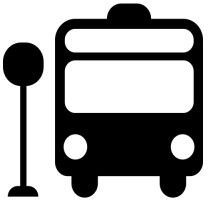

BUS STOP



COMMUNITY GARDEN



Lodi Library Plot Rendering



DINING ROOM

OPEN

EVENING
FISHERY!!
FRIDAY
S & R!!
JILLHEADS
HERE!!

Eagle Hotel Now



POTTED
PLANTS



BENCHES

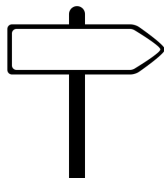

SIGNAGE



Eagle Hotel Rendering



**SENECA WINE
TASTING ROOM**



Seneca Wine Tasting Room Rendering

Final Report

S
T
E
P
S



Acknowledgements

Seneca Towns Engaging People for Solutions (STEPS)
Seneca County Cornell Cooperative Extension (SCCCE)
Village and Town of Lodi Residents
Cornell University Design Connect Board
Professor Michael Tomlan, City and Regional Planning
Hobum Moon, Landscape Architecture, 2015

Team Members:

Hadar Sachs
Victoria Phillips
Christine Ma
Jason Spencer
Heekyung Hahn
Kathryn Smith
Zhiyin Pan
Hien Dinh
Bridgit Hohlfeld
Daniel Keough

Questions?

